

DXN MARKETING PLAN

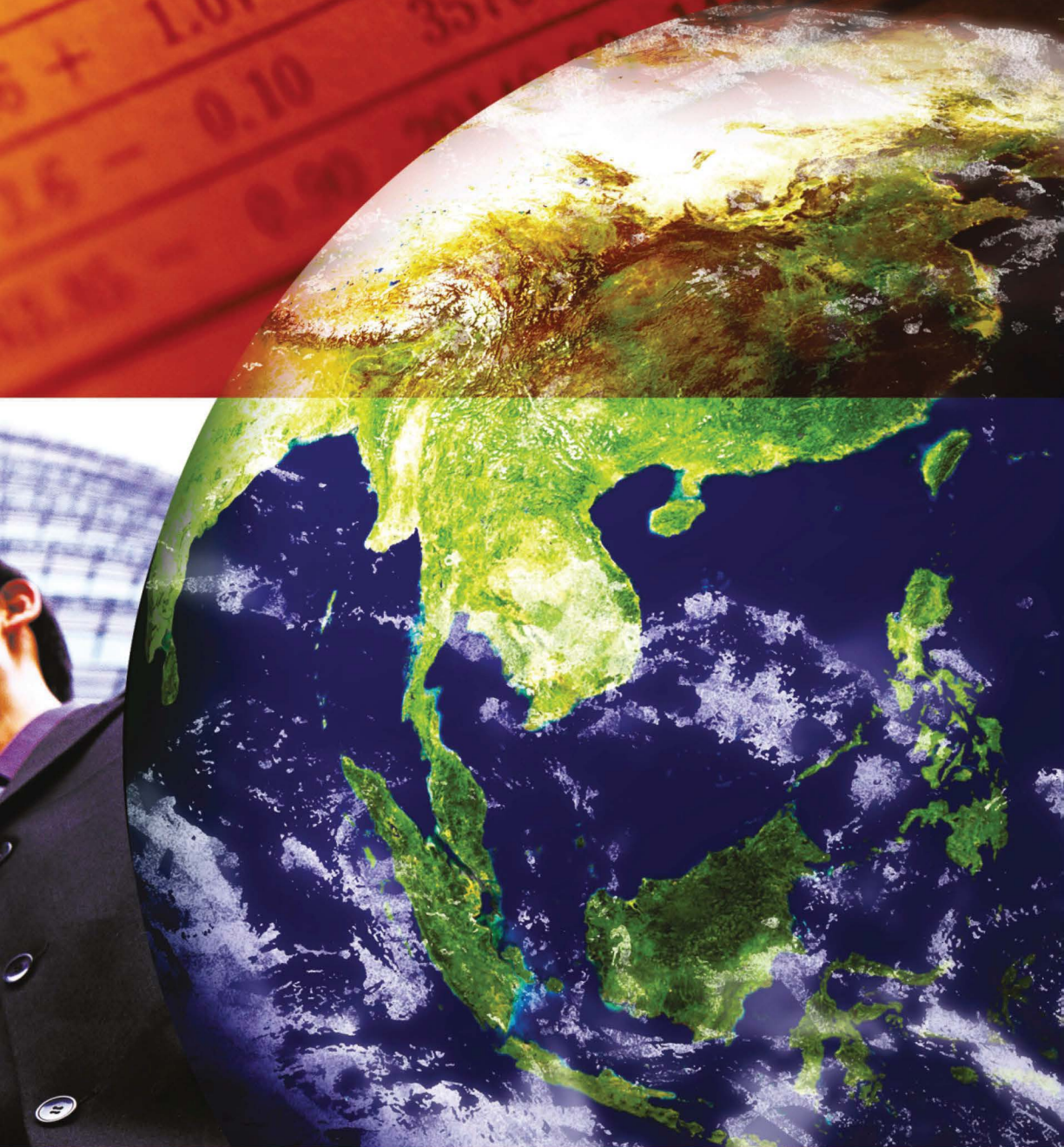

DXN Marketing India Private Limited
www.dxnindia.in

Dear Distributor,

Welcome to the DXN family !

Congratulations, for making a right choice of taking a quantum leap towards financial independence and time flexibility with DXN. We believe both are within your reach as you have taken the crucial step to join in our business.

DXN practices the concept of "**One World One Market**" where you will have the opportunity to expand your business not only in your country but the world over to enjoy worldwide business with a single distributor card.

At DXN, we uphold the philosophy of providing **Low price, High Quality** products while generating **High Income** by applying cutting edge practices in Multilevel Marketing to ensure top Performance. We believe this business idea has spillover effects that will reach out to those who strive for better health financial freedom and personal achievement.

We believe that if we work together, we can achieve

HEALTH ! WEALTH ! AND SUCCESS

Once again, our Management and staff would like to extend a warm welcome to you for joining our DXN global family.

See you at the Top,

Thank you,

Management
DXN Marketing India Pvt Ltd.

DXN MARKETING PLAN

Definition of Terms

- PV** : Point Value, for qualification and status.
- SV** : Sales Value, for calculation of Bonus and Incentive.
- Personal Point Value (PPV) / Personal Sales Value (PSV)** : Total PV/SV generated from all personal cash bills transacted in a month.
- Personal Group Point Value (PGPV) / Personal Group Sales Value (PGSV)** : Total PV/SV generated in a month by all downline distributors within personal group (ie. excluding breakaway QSAs) and own PPV/PSV.
- Diamond Group Point Value (DGPV) / Diamond Group Sales Value (DGSV)** : Total PV/SV generated in a month by all downline distributors within your diamond group (ie. excluding breakaway QSDs) and own PPV/PSV.
- Qualified Star Agent (QSA)** : Any SA who maintains 1,000PPV and 3,000PGPV in a month.
- Qualified Star Diamond (QSD)** : Any Diamond who qualifies for 37% Star Group Bonus.
- Travel Seminar Qualifier** : Any SA and above who meets the Yearly Travel Seminar Incentive Points (TSIP) Quota set of the year.

Introduction Of Remuneration

1) Retail Profit ----- > 15%

2) Bonus (71%) and Cash Incentive (Rs.135,000)

a) Group Bonus -----	6% - 21%
b) Star Group Bonus -----	25% - 37%
c) Development Bonus -----	15%
d) Group Incentive -----	2%
e) Leadership Bonus -----	15%
f) Travel Seminar Incentive -----	2%
g) One Time HP Cash Incentive -----	Rs.15,000
h) One Time Overseas Trip Cash Incentive-----	Rs.120,000

Status

Status	Condition
Distributor	Age 18 years and a sponsor.
Star Agent (SA)	Achieves accumulated Group Sales of 45,000PV
Star Ruby (SR)	Sponsors 3 First Generation Star Agents (SA)
Star Diamond (SD)	With 6 First Generation Star Agents (SA) & qualifies for 37% Star Group Bonus.
Executive Star Diamond (ESD)	Star Diamond who sponsors 1 Star Diamond
Senior Star Diamond (SSD)	Star Diamond who sponsors 2 Star Diamonds*
Executive Senior Star Diamond (ESSD)	Star Diamond who sponsors 3 Star Diamonds*
Double Diamond (DD)	Star Diamond who sponsors 4 Star Diamonds*
Executive Double Diamond (EDD)	Star Diamond who sponsors 5 Star Diamonds*
Triple Diamond (TD)	Star Diamond who sponsors 6 Star Diamonds*
Executive Triple Diamond (ETD)	Star Diamond who sponsors 7 Star Diamonds*
Gold Diamond (GD)	Star Diamond who sponsors 8 Star Diamonds*
Executive Gold Diamond (EGD)	Star Diamond who sponsors 9 Star Diamonds*
Crown Diamond (CD)	Star Diamond who sponsors 10 Star Diamonds*
Executive Crown Diamond (ECD)	Star Diamond who sponsors 11 Star Diamonds*
Senior Crown Diamond (SCD)	Star Diamond who sponsors 12 Star Diamonds*
Executive Senior Crown Diamond (ESCD)	Star Diamond who sponsors 13 Star Diamonds*
Double Crown Diamond (DCD)	Star Diamond who sponsors 14 Star Diamonds*
Executive Double Crown Diamond (EDCD)	Star Diamond who sponsors 15 Star Diamonds*
Triple Crown Diamond (TCD)	Star Diamond who sponsors 16 Star Diamonds*
Executive Triple Crown Diamond (ETCD)	Star Diamond who sponsors 17 Star Diamonds*
Gold Crown Diamond (GCD)	Star Diamond who sponsors 18 Star Diamonds*
Executive Gold Crown Diamond (EGCD)	Star Diamond who sponsors 19 Star Diamonds*
Crown Ambassador (CA)	Star Diamond who sponsors 20 Star Diamonds*

* As per dynamic compression.

Remuneration in DXN Marketing Plan

1. Retail Profit (> 15%)

Direct profit for distributors is when they sell DXN products to non-DXN members. Retail profit is the difference between distributor price and maximum retail price.

2. Group Bonus (6% - 21%)

To be entitled for this Group Bonus, you need to maintain 1,000PPV each month.

Accumulated Group PV	Bonus
45,000 and above	21%*
32,500	18%
20,000	15%
10,000	12%
3,000	9%
1,000	6%

* If a Star Agent (21%) maintains 1,000PPV and 3,000PGPV **, he will become a Qualified Star Agent (25%).

3. Star Group Bonus (25% - 37%)

*To be entitled for this Star Group Bonus, you must be a SA and maintain 1,000PPV and 3,000PGPV** (QSA) each month.*

No. of SA (1st Generation)	No. of Qualified SA Lines	DGPV	Bonus
6	-	50,000	37%
	4	25,000 #	
5	-	30,000	35%
	4	20,000	
4	4	-	33%
3	3	-	31%
2	2	-	29%
1	1	-	27%
0	0	-	25%

** PGPV is inclusive of personal PV (i.e. 1,000PPV + 2,000 non-QSA group PV).

For SSD and above, if the number of QSD is more than one, then the DGPV can be borrowed from one of the QSD and the number of QSD will be reduced by one.

4. Development Bonus (15%)

*To be entitled for this Development Bonus, you must be a SA and maintain 1,000PPV and 3,000PGPV** (QSA) each month*

Level of Qualified SA	Bonus
1st Level	5%
2nd Level	4%
3rd Level	3%
4th Level	2%
5th Level	1%

PGPV is inclusive of personal PV (i.e. 1,000PPV + 2,000 non-QSA group PV).

5. Group Incentive (2%)

To be entitled for this Group Incentive (GI) you must be a Qualified Star Diamond (QSD)

GI Fund = Overall Company's Sales in SV X 2%

Your GI entitlement

$$= \text{GI Fund} \times \frac{\text{Your GI Point for the month}}{\text{Total GI Point for all Qualified Star Diamonds and above}}$$

- Your GI Point calculation:

Level of Qualified SD	GI Point			
Personal			DGSV X	100%
1st Level QSD (L1)	+	L1	DGSV X	50%
2nd Level QSD (L2)	+	L2	DGSV X	40%
3rd Level QSD (L3)	+	L3	DGSV X	30%
4th Level QSD (L4)	+	L4	DGSV X	20%
5th Level QSD (L5)	+	L5	DGSV X	10%

7. Travel Seminar Incentive (2%)

This Travel Seminar Incentive(TSI) shall be used by the qualifier for the travel seminar organised by the Company only. It is not exchangeable for cash and also not transferable. A qualifier may claim up to maximum Travel Seminar Fare against his/her TSI for two(2) if married.

$$\text{Travel Seminar Incentive Fund} = \text{Company's Annual Sales in SV} \times 2\%$$

• To be shared as below:

- i) 50% of the Travel Seminar Incentive Fund (TSIF) to be shared amongst all SA and above who met the YEARLY TSIP QUOTA set for the year.
- ii) 50% of the Travel Seminar Incentive Fund (TSIF) to be shared amongst all SD and above who met the YEARLY TSIP QUOTA set for the year.

a) Travel Seminar Incentive for SA Qualifier (TSI_{SA})

$$TSI_{SA} = 50\% \times TSIF \times \frac{\text{Accumulated TSIP* for a SA Qualifier}}{\text{Total Accumulated TSIP for all SA Qualifiers}}$$

* Travel Seminar Incentive Point (TSIP) will be calculated monthly based on the following formula and to be accumulated for a year:

Level of Qualified SA	Monthly Travel Seminar Incentive Point (TSIP)			
Personal			PGSV	X 100%
1st Level QSA (L1)	+	L1	PGSV	X 50%
2nd Level QSA (L2)	+	L2	PGSV	X 40%
3rd Level QSA (L3)	+	L3	PGSV	X 30%
4th Level QSA (L4)	+	L4	PGSV	X 20%
5th Level QSA (L5)	+	L5	PGSV	X 10%

b) Travel Seminar Incentive for SD Qualifier (TSI_{SD})

$$TSI_{SD} = 50\% \times TSIF \times \frac{\text{Accumulated TSIP* for a SD Qualifier}}{\text{Total Accumulated TSIP for all SD Qualifiers}}$$

* Travel Seminar Incentive Point (TSIP) will be calculated monthly based on the following formula and to be accumulated for a year:

Level of Qualified SD	Monthly Travel Seminar Incentive Point (TSIP)			
Personal			DGSV	X 100%
1st Level QSD (L1)	+	L1	DGSV	X 50%
2nd Level QSD (L2)	+	L2	DGSV	X 40%
3rd Level QSD (L3)	+	L3	DGSV	X 30%
4th Level QSD (L4)	+	L4	DGSV	X 20%
5th Level QSD (L5)	+	L5	DGSV	X 10%

8. Hand Phone Cash Incentive (Rs.15,000) - One Time Only

When you have 3 immediate SA's who achieved 60,000 Accumulated GPV, then you will be entitled to receive this **One Time** Hand Phone Cash Incentive amounting to Rs.15,000.

* Only personally sponsored downlines counted.

9. Overseas Trip Cash Incentive (Rs.120,000) - One Time Only

When you have 5 immediate downlines who have received their Hand Phone Cash Incentive, then you will be entitled to receive this **One Time** Overseas Trip Cash Incentive amounting to Rs.120,000.

* Only personally sponsored downlines counted.

Explanation On The DXN Marketing Plan Reward

1. Retail Profit (>15%)

Direct profit for distributors is when they sell DXN products to non-DXN members. Retail profit is the difference between distributor price and maximum retail price.

Example:

If you sell one unit of DXN Product to a non-DXN distributor, you will earn the retail profit as below:

One unit of DXN Product	
Distributor Price	Rs.250
Maximum Retail Price	Rs.300

Therefore,

Maximum Retail Price – Distributor Price = Retail Profit
Rs.300 – Rs.250 = Rs.50

YOUR retail profit is Rs.50 (20% from distributor price)

"The statements made on this page are hypothetical and merely meant to describe and explain the mechanisms of the Compensation plan and its various bonus features. Any statements made on this page are not meant as earnings claims, nor do they represent any promises or guarantees of specific earnings or earning potential. Specific earnings will be influenced by many factors."

* Assume 1PV = 1SV for all the following Bonuses and Incentives calculations.

2. Group Bonus (6%-21%)

CASE 1

If in the first month you have acquired 1,000PV and sponsored 3 new distributors with 5,000PV each:

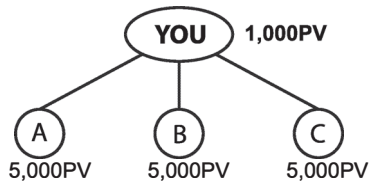

Personal PV/SV (PPV/PSV) = 1,000PV/SV
 Personal Group PV/SV (PGPV/PGSV) = 16,000PV/SV

Your Group Bonus = (16,000SV X 12%) - (5,000SV X 9%)
 = (5,000SV X 9%) - (5,000SV X 9%)
 = Rs.1,920 - Rs.450 - Rs.450 - Rs.450
 = Rs.570

Therefore:

Your Group Bonus is Rs.570 and Group Bonus for A, B and C is Rs.450 each.

CASE 2

If YOU have acquired 600PV and each one of your downline achieved 5,000PV:

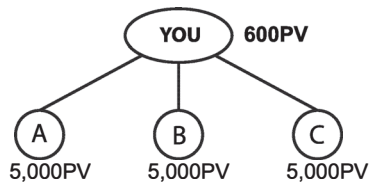

Personal PV/SV (PPV/PSV) = 600PV/SV
 Personal Group PV/SV (PGPV/PGSV) = 15,600PV/SV

You are not qualified to receive any bonus because your Personal PV is less than 1,000PPV. To qualify for Group Bonus, YOU must have a minimum of 1,000PPV.

"The statements made on this page are hypothetical and merely meant to describe and explain the mechanisms of the Compensation plan and its various bonus features. Any statements made on this page are not meant as earnings claims, nor do they represent any promises or guarantees of specific earnings or earning potential. Specific earnings will be influenced by many factors."

3. Star Group Bonus (25% - 37%)



If YOU are a Star Ruby (SR) and have sponsored 3 Star Agents (SA) and 2 distributors:

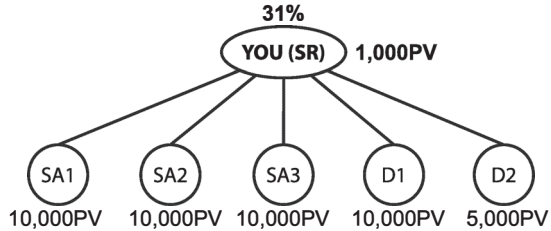

Personal PV/SV (PPV/PSV) = 1,000PV/SV
 Personal Group PV/SV (PGPV/PGSV) = 16,000PV/SV

Your Star Group Bonus = (46,000SV X 31%) - (10,000SV X 25%)
 - (10,000SV X 25%) - (10,000SV X 25%)
 - (10,000SV X 12%) - (5,000SV X 9%)
 = Rs.14,260 - Rs.2,500 - Rs.2,500
 - Rs. 2,500 - Rs.1,200 - Rs.450
 = Rs.5,110

Therefore:

YOUR Star Group Bonus is Rs.5,110.

SA1, SA2 and SA3 will earn Rs.2,500 each.

Group Bonus for D1 is Rs.1,200 and D2 is Rs.450.

CASE 2

If YOU are a Star Diamond with 6 SAs (1st Generation), 1,000PPV and 4,000PGPV. At the same time, YOU have some downlines with the status of Star Ruby (SR) and Star Agent (SA) who have at least 1,000PPV.

The Star Group Bonus entitlement (%) for YOU and your downlines will be as follow:

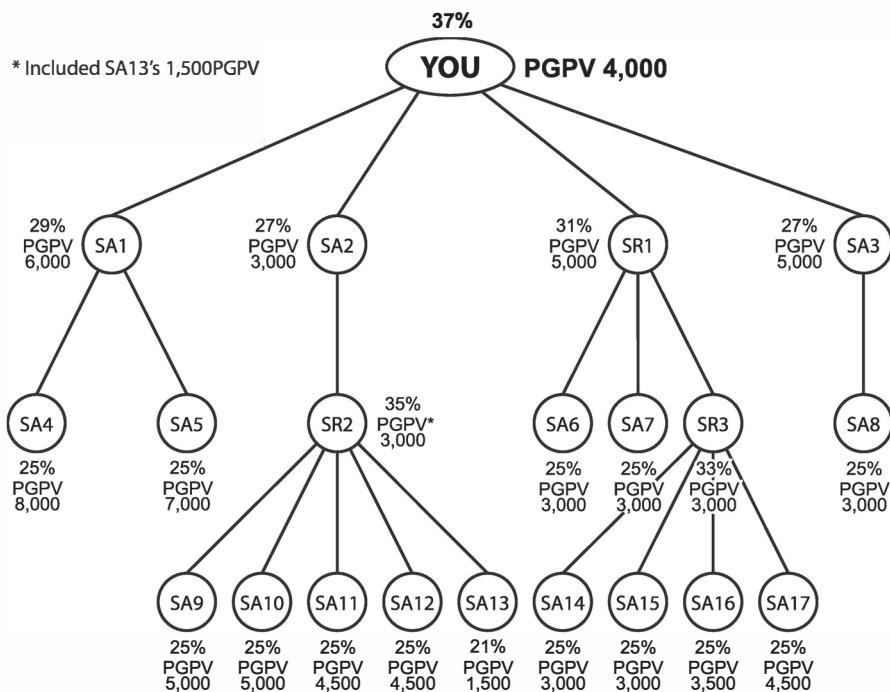

Star Group Bonus (%)

	Status	No of Qualified SA Lines	PPV	PGPV	DGPV	SGB entitlement (%)
YOU	SD	4	1,000	4,000	86,000	37%
SA1	SA	2	1,000	6,000		29%
SA2	SA	1	1,000	3,000		27%
SR1	SR	3	1,000	5,000	28,000	31%
SR2	SR	4	1,000	3,000	22,000	35%
SR3	SR	4	1,000	3,000	17,000	33%
SA4	SA	0	1,000	8,000		25%
SA13	SA	0	1,000	1,500		21%

"The statements made on this page are hypothetical and merely meant to describe and explain the mechanisms of the Compensation plan and its various bonus features. Any statements made on this page are not meant as earnings claims, nor do they represent any promises or guarantees of specific earnings or earning potential. Specific earnings will be influenced by many factors."

CASE 3

If YOU are a Star Ruby (SR) with 5 SAs (1st Generation), 1,000PPV and 5,000PGPV. At the same time, YOU have downlines with the status of Star Ruby (SR) and Star Agent (SA). Some of the SR or SA are inactive (i.e. SA1, SA2, SA5 & SR)

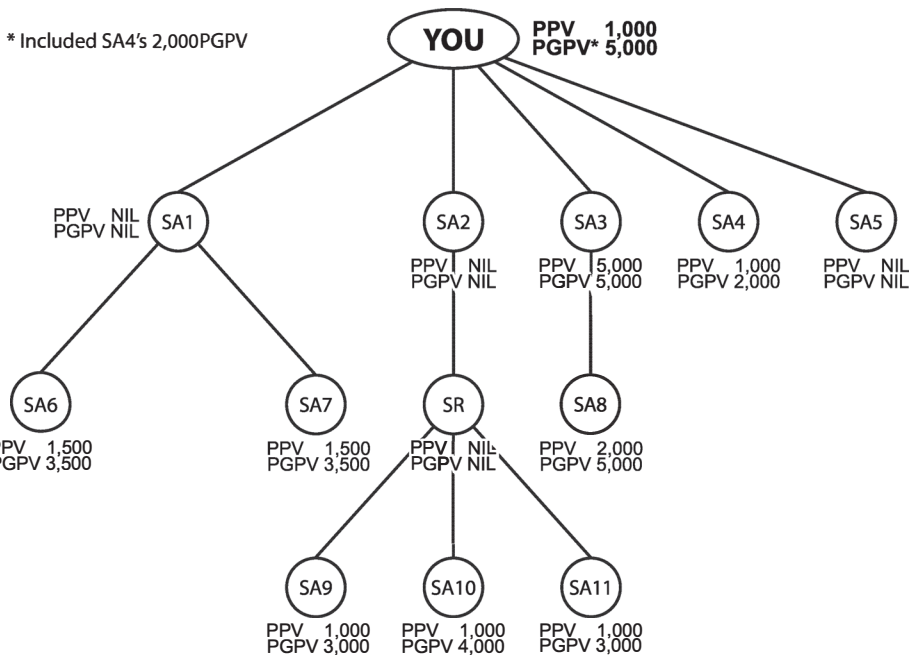

Therefore, YOU are entitled to 35% of Star Group Bonus even you have only 3 qualified SA lines. It is because YOU have 5 SAs (1st Generation) and obtained 32,000 DGPV.

"The statements made on this page are hypothetical and merely meant to describe and explain the mechanisms of the Compensation plan and its various bonus features. Any statements made on this page are not meant as earnings claims, nor do they represent any promises or guarantees of specific earnings or earning potential. Specific earnings will be influenced by many factors."

4. Development Bonus (15%)

CASE 1

For Development Bonus, if YOU are a Star Ruby (SR) and have downlines as below:

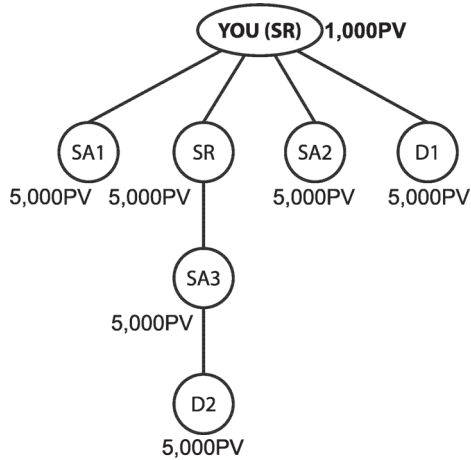

Personal PV/SV (PPV/PSV) = 1,000PV/SV
 Personal Group PV/SV (PGPV/PGSV) = 6,000PV/SV

YOUR Development Bonus = (15,000SV x 5%) + (10,000SV x 4%)
 = Rs.750 + Rs.400
 = Rs.1,150

Therefore:
YOUR Development Bonus is Rs.1,150

"The statements made on this page are hypothetical and merely meant to describe and explain the mechanisms of the Compensation plan and its various bonus features. Any statements made on this page are not meant as earnings claims, nor do they represent any promises or guarantees of specific earnings or earning potential. Specific earnings will be influenced by many factors."

CASE 2

For Development Bonus, if YOU are a Star Ruby (SR) and have downlines as below:

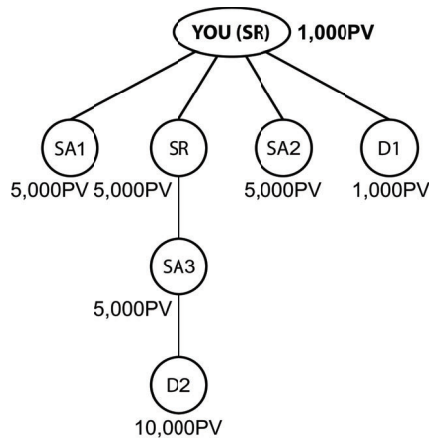

Personal PV/SV (PPV/PSV) = 1,000PV/SV

Personal Group PV/SV (PGPV/PGSV) = 2,000PV/SV

Therefore:

YOU are not qualified to earn the development bonus because your Personal PV is less than 3,000PV.

"The statements made on this page are hypothetical and merely meant to describe and explain the mechanisms of the Compensation plan and its various bonus features. Any statements made on this page are not meant as earnings claims, nor do they represent any promises or guarantees of specific earnings or earning potential. Specific earnings will be influenced by many factors."

5. Group Incentive (2%)



YOU are a Senior Star Diamond (SSD) and have downlines of Star Diamond (SD) and above.

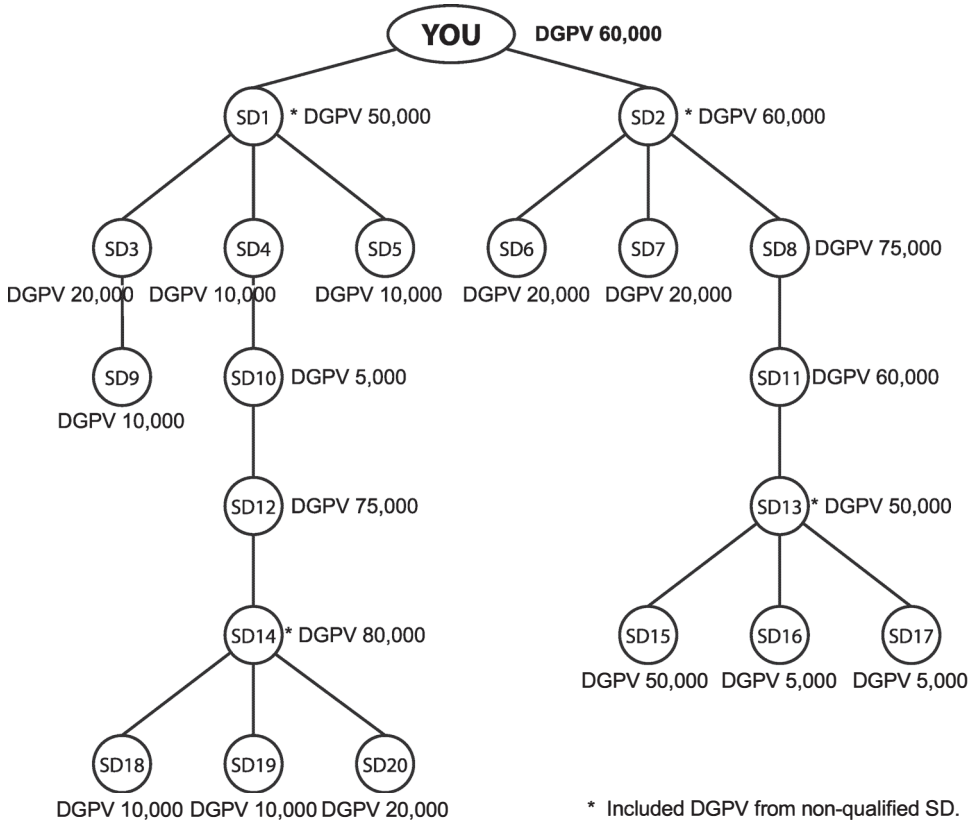

Non-qualified SD: SD3, SD4, SD5, SD6, SD7, SD9, SD10, SD16, SD17, SD18, SD19 & SD20
 Qualified SD : YOU, SD1, SD2, SD8, SD11, SD12, SD13, SD14 & SD15

"The statements made on this page are hypothetical and merely meant to describe and explain the mechanisms of the Compensation plan and its various bonus features. Any statements made on this page are not meant as earnings claims, nor do they represent any promises or guarantees of specific earnings or earning potential. Specific earnings will be influenced by many factors."

Assumptions:-

- i) 1PV equals to 1SV.
- ii) There are 68 Star Diamonds and above in the company and the Total GI Point is 5,000,000 points.
- iii) Total company's sales for that particular month is 20,000,000SV.

GI Point for YOU:

	DGSV			GI points
YOU	60,000	X	100%	= 60,000
1st Level: SD1 + SD2	110,000	X	50%	= 55,000
2nd Level: SD12 + SD8	150,000	X	40%	= 60,000
3rd Level: SD14 + SD11	140,000	X	30%	= 42,000
4th Level: SD13	50,000	X	20%	= 10,000
5th Level: SD15	50,000	X	10%	5,000
YOUR Total GI Point				<u>232,000</u>

Therefore:

YOUR Group Incentive

$$\begin{aligned}
 &= \text{GI FUND X } \frac{\text{Your GI Point for the month}}{\text{Total GI Point for all Qualified Star Diamond \& above}} \\
 &= 2\% \text{ X } 20,000,000\text{SV} \text{ X } \frac{232,000\text{pts}}{5,000,000\text{pts}} \\
 &= \underline{\underline{\text{Rs.18,560}}}
 \end{aligned}$$

"The statements made on this page are hypothetical and merely meant to describe and explain the mechanisms of the Compensation plan and its various bonus features. Any statements made on this page are not meant as earnings claims, nor do they represent any promises or guarantees of specific earnings or earning potential. Specific earnings will be influenced by many factors."

6. Leadership Bonus (15%)

CASE 1

YOU are an Executive Senior Star Diamond (ESSD) and have qualified for 37% Star Group Bonus.

Every Circle (from A1 to C6) represents a SD and above.

All SDs have qualified for 37% Star Group Bonus.

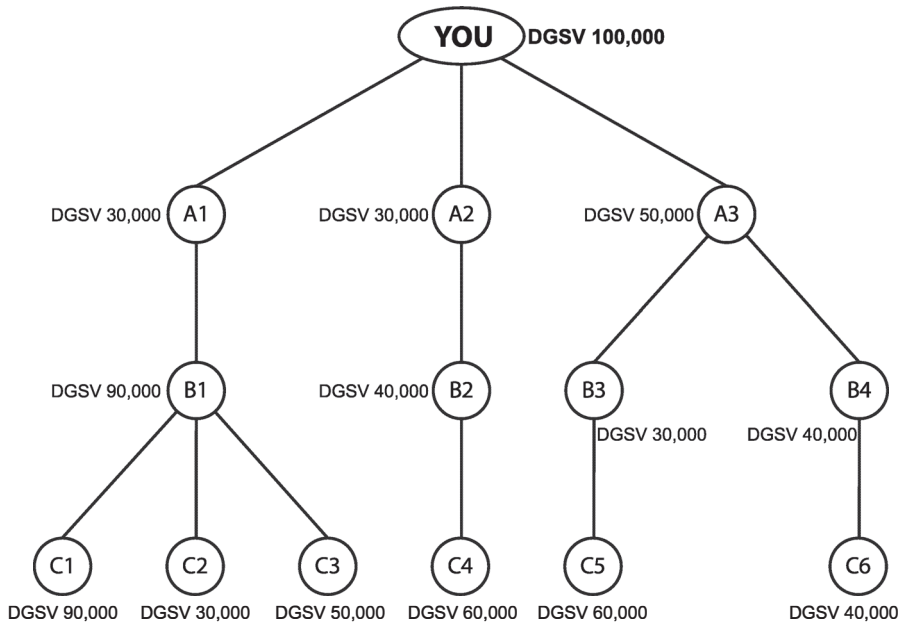

YOUR Leadership Bonus:

1st Level qualified SD:

$$A1 + A2 + A3 = 110,000\text{SV} \times 5.0\% = \text{Rs. } 5,500$$

2nd Level and below qualified SD:

$$B1 + C1 + C2 + C3 + B2 + C4 + B3 + B4 = 430,000\text{SV} \times 4.8\% = \text{Rs. } 20,640$$

$$C5 + C6 = 100,000\text{SV} \times 1.8\% = \text{Rs. } 1,800$$

YOUR Leadership Bonus

Rs.27,940

"The statements made on this page are hypothetical and merely meant to describe and explain the mechanisms of the Compensation plan and its various bonus features. Any statements made on this page are not meant as earnings claims, nor do they represent any promises or guarantees of specific earnings or earning potential. Specific earnings will be influenced by many factors."

CASE 2

YOU are an Executive Double Diamond (EDD) and have qualified for 37% Star Group Bonus. Every Circle (from A1 to C6) represents a SD and above. All SDs have qualified for 37% Star Group Bonus with the exception of A1, A2, A5, & B5.

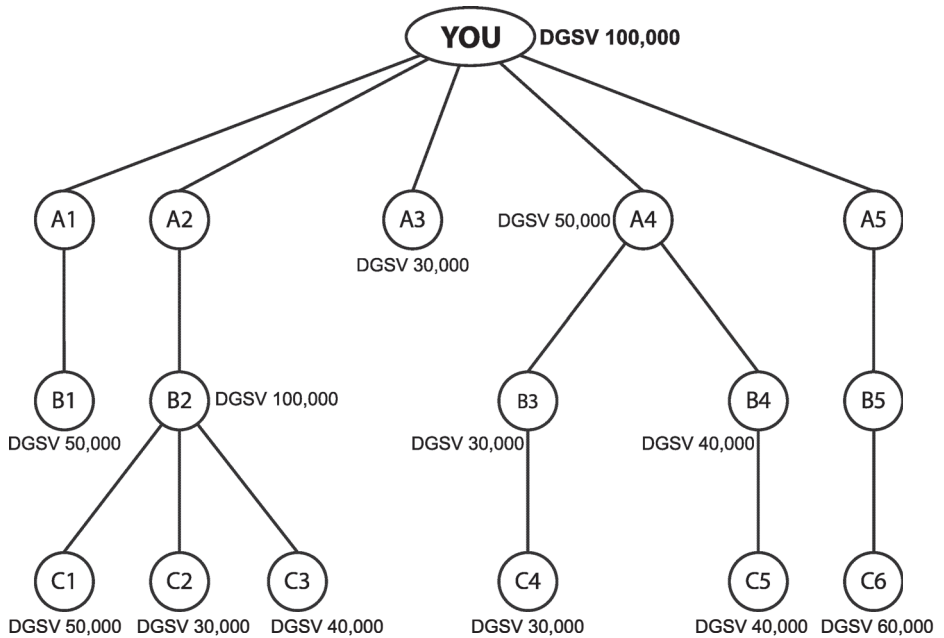

YOUR Leadership Bonus:

1st Level qualified SD:
B1 + B2 + A3 + A4 + C6

$$= 290,000\text{SV} \times 5.0\% = \text{Rs.14,500}$$

2nd Level and below qualified SD:
C1 + C2 + C3 + B3 + B4
C4 + C5

$$= 190,000\text{SV} \times 6.5\% = \text{Rs.12,350}$$

$$= 70,000\text{SV} \times 3.5\% = \text{Rs. 2,450}$$

YOUR Leadership Bonus

Rs.29,300

"The statements made on this page are hypothetical and merely meant to describe and explain the mechanisms of the Compensation plan and its various bonus features. Any statements made on this page are not meant as earnings claims, nor do they represent any promises or guarantees of specific earnings or earning potential. Specific earnings will be influenced by many factors."

CASE 3

YOU are an Executive Double Diamond (EDD) and have qualified for 37% Star Group Bonus. Every Circle (from A1 to C6) represents a SD and above. All SDs have qualified for 37% Star Group Bonus with the exception of A1, A2, A5, & B5.

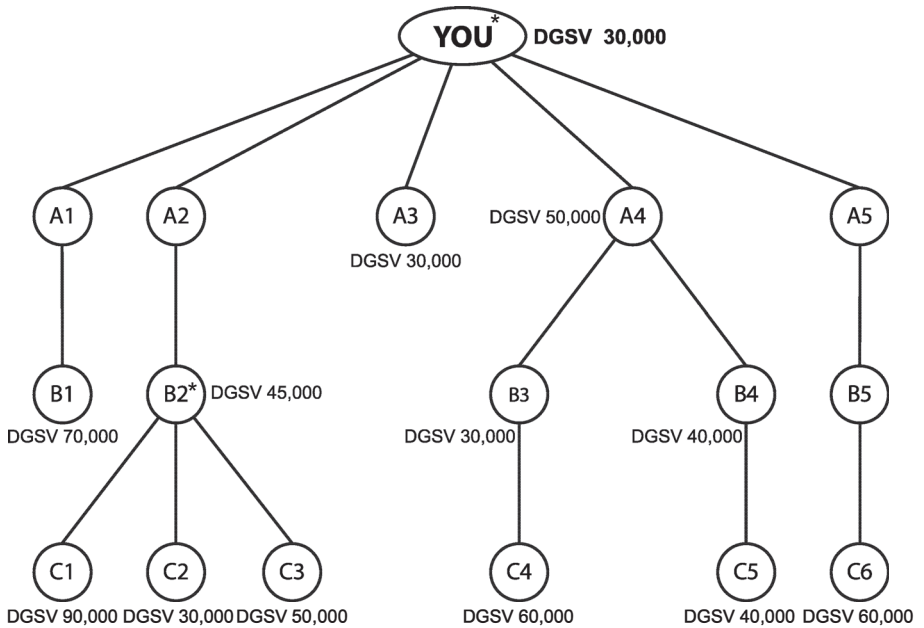

YOUR Leadership Bonus:

1st Level qualified SD: B1 + B2 + A3 + A4 + C6	255,000SV		
Add: Guarantee from Downline (B2)	30,000SV		
Less: Guarantee Upline (YOU)	(70,000SV)		
	<u>215,000SV</u>	X 5.0%	= Rs.10,750
2nd Level and below qualified SD: C1 + C2 + C3 + B3 + B4	240,000SV		
Less: Guarantee Upline (B2)	(30,000SV)		
	<u>210,000SV</u>	X 6.5%	= Rs.13,650
C4 + C5	100,000SV	X 3.5%	= Rs. 3,500
YOUR Leadership Bonus			<u>Rs.27,900</u>

* YOU need to guarantee upline 100,000DGSV.

* B2 need to guarantee upline 75,000DGSV.

"The statements made on this page are hypothetical and merely meant to describe and explain the mechanisms of the Compensation plan and its various bonus features. Any statements made on this page are not meant as earnings claims, nor do they represent any promises or guarantees of specific earnings or earning potential. Specific earnings will be influenced by many factors."

CASE 4

YOU are a Crown Ambassador (CA) and have 20 first generation Crown Ambassadors (CAs) with 100,000DGSV each. All CAs have 20 Qualified SDs with 100,000DGSV each.

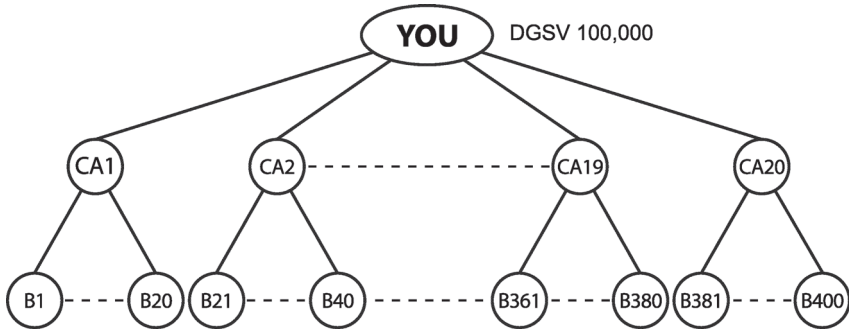

Therefore:

Your Leadership Bonus

1st Level Qualified SD: 100,000DGSV X 20 X 5%	=	Rs. 100,000
2nd Level Qualified SD: 100,000DGSV X 400 X 10%	=	Rs.4,000,000
		<u>Rs.4,100,000</u>

"The statements made on this page are hypothetical and merely meant to describe and explain the mechanisms of the Compensation plan and its various bonus features. Any statements made on this page are not meant as earnings claims, nor do they represent any promises or guarantees of specific earnings or earning potential. Specific earnings will be influenced by many factors."

7. One Time Hand Phone Cash Incentive



After you have sponsored 3 immediate SAs who achieved 60,000 Accumulated GPV.

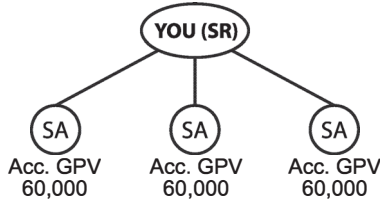

Therefore:

YOU are qualified to receive the One Time Hand Phone Cash Incentive amounting to Rs.15,000.

8. One Time Overseas Trip Cash Incentive



After you have 5 immediate downlines who have received their Hand Phone Cash Incentive, then you are qualified for this One Time Overseas Trip Cash Incentive.

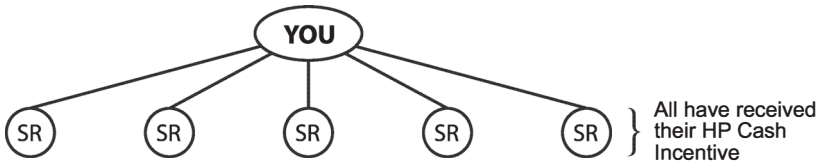

Therefore:

Once YOU have fulfilled the requirements, YOU are qualified for One Time Overseas Trip Cash Incentive amounting to Rs.120,000.

"The statements made on this page are hypothetical and merely meant to describe and explain the mechanisms of the Compensation plan and its various bonus features. Any statements made on this page are not meant as earnings claims, nor do they represent any promises or guarantees of specific earnings or earning potential. Specific earnings will be influenced by many factors."

How to become a Star Diamond within 5 months

Assumptions:-

- Personal Sales for each distributor is 1,000PPV per month.
- Each distributor have 3 new distributors in each month.
- 1PV = 1SV

1st Month

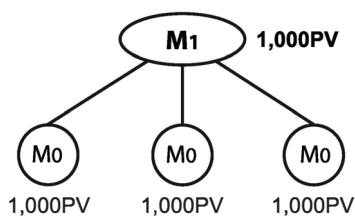

Your status : Distributor - 4,000PGPV (9%)

Personal PV/SV (PPV/PSV) = 1,000PV/SV
 Personal Group PV/SV (PGPV/PGSV) = 4,000PV/SV
 Accumulated PGPV = 4,000PV

Your Bonus Income			
Group Bonus	=	4,000SV X 9%	= Rs.360
Less: Downlines Bonus	=	(3 X 1,000SV X 6%)	= (Rs.180)
YOUR Bonus Income			<u>Rs.180</u>

"The statements made on this page are hypothetical and merely meant to describe and explain the mechanisms of the Compensation plan and its various bonus features. Any statements made on this page are not meant as earnings claims, nor do they represent any promises or guarantees of specific earnings or earning potential. Specific earnings will be influenced by many factors."

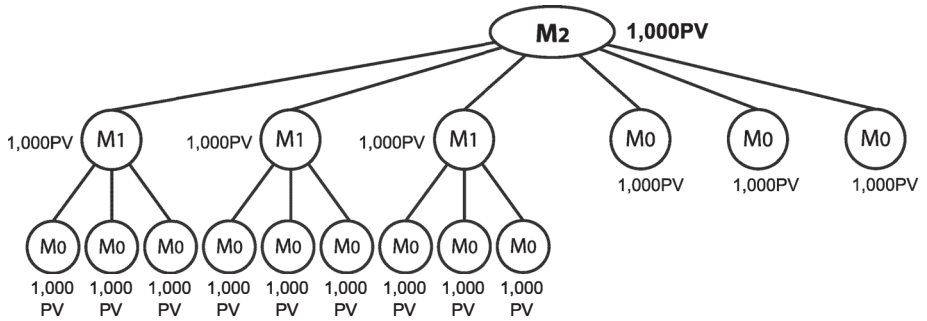

Your status : Distributor - Accumulated 20,000 PGPV (15%)

Personal PV/SV (PPV/PSV) = 1,000PV/SV
 Personal Group PV/SV (PGPV/PGSV) = 16,000PV/SV
 Accumulated PGPV b/f = 4,000PV
 Accumulated PGPV c/f = 20,000PV

Your Bonus Income

Group Bonus = 16,000SV X 15% = Rs.2,400
 Less: Downlines Bonus = (4,000SV X 9% X 3) + (1,000SV X 6% X 3) = (Rs.1,260)

YOUR Bonus Income Rs.1,140

"The statements made on this page are hypothetical and merely meant to describe and explain the mechanisms of the Compensation plan and its various bonus features. Any statements made on this page are not meant as earnings claims, nor do they represent any promises or guarantees of specific earnings or earning potential. Specific earnings will be influenced by many factors."

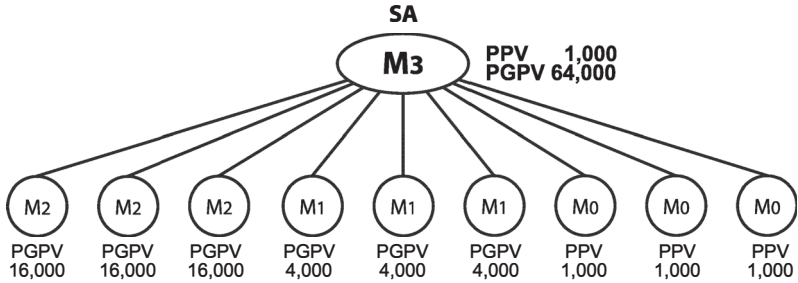

Congratulations! You have reached 45,000 Accumulated PGPV and you are now a Star Agent.

Personal PV/SV (PPV/PSV) = 1,000PV/SV
 Personal Group PV/SV (PGPV/PGSV) = 64,000PV/SV
 Accumulated PGPV b/f = 20,000PV
 Accumulated PGPV c/f = 84,000PV

Your Bonus Income
 Group Bonus = 64,000SV X 25% = Rs.16,000
 Less: Downlines Bonus = (16,000SV X 15% X 3) + (4,000SV X 9% X 3) + (1,000SV X 6% X 3) = (Rs.8,460)

YOUR Bonus Income Rs.7,540

"The statements made on this page are hypothetical and merely meant to describe and explain the mechanisms of the Compensation plan and its various bonus features. Any statements made on this page are not meant as earnings claims, nor do they represent any promises or guarantees of specific earnings or earning potential. Specific earnings will be influenced by many factors."

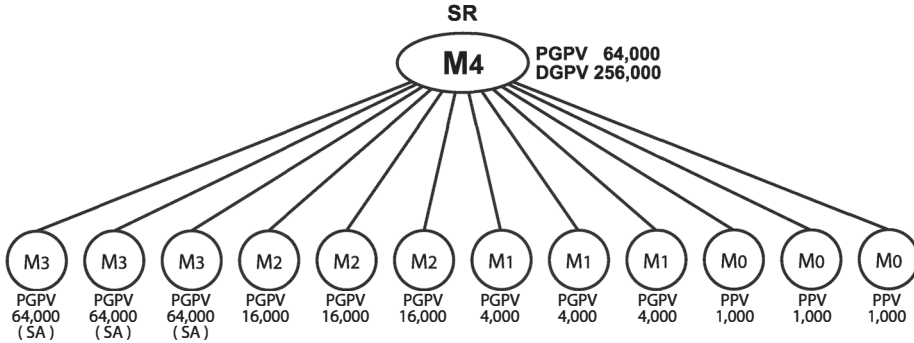

Congratulations! You have successfully promoted 3 direct Star Agent under you, and therefore you are now a Star Ruby.

Personal PV/SV (PPV/PSV) = 1,000PV/SV
 Personal Group PV/SV (PGPV/PGSV) = 64,000PV/SV
 Diamond Group PV/SV (DGPV/DGSV) = 256,000PV/SV

Your Bonus Income	=	256,000SV X 31%	=	Rs.79,360
Star Group Bonus	=	(64,000SV X 25% X 3)		
Less: Downlines Bonus	=	+ (16,000SV X 15% X 3)		
		+ (4,000SV X 9% X 3)		
		+ (1,000SV X 6% X 3)	=	(Rs.56,460)
				Rs.22,900
Development Bonus	=	64,000SV X 5% X 3	=	Rs. 9,600
HP Cash Incentive				Rs.15,000
Your Bonus Income				<u>Rs.47,500</u>

"The statements made on this page are hypothetical and merely meant to describe and explain the mechanisms of the Compensation plan and its various bonus features. Any statements made on this page are not meant as earnings claims, nor do they represent any promises or guarantees of specific earnings or earning potential. Specific earnings will be influenced by many factors."

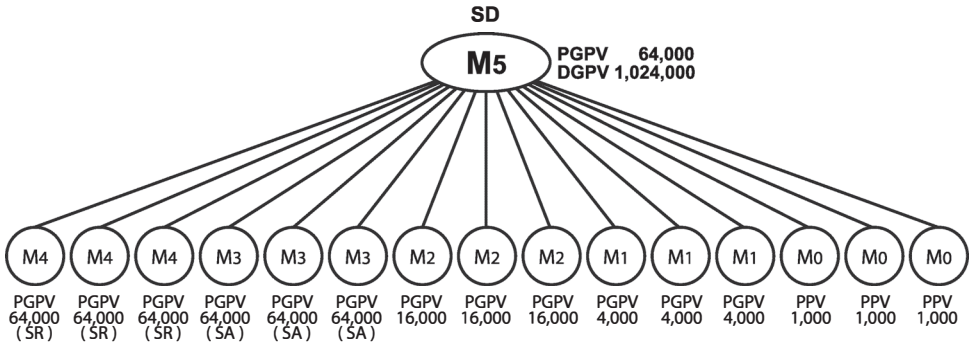

Congratulations! You have successfully promoted 6 SA (1st Generation) and have also met the 50,000 DGPV quota. Hence, you are now a Star Diamond.

Personal PV/SV (PPV/PSV) = 1,000PV/SV
 Personal Group PV/SV (PGPV/PGSV) = 64,000PV/SV
 Diamond Group PV/SV (DGPV/DGSV) = 1,024,000PV/SV

Your Bonus Income

(A) Star Group Bonus = 1,024,000SV X 37% = Rs.378,880
 Less: Downlines Bonus = (256,000SV X 31% X 3)
 + (64,000SV X 25% X 3)
 + (16,000SV X 15% X 3)
 + (4,000SV X 9% X 3)
 + (1,000SV X 6% X 3) = (Rs.294,540) **Rs.84,340**

(B) Development Bonus
 1st Level = 64,000SV X 6 X 5% = Rs.19,200
 2nd Level = 64,000SV X 9 X 4% = Rs.23,040 **Rs.42,240**

(C) Group Incentive
 Assumption:-
 i) GI Fund = Rs.400,000
 ii) Total GI Point for all Qualifiers = 50,000,000pts
 iii) YOUR GI Point for the month = 1,024,000 SV X 100%
 = 1,024,000 pts

Your Group Incentive
 = Rs.400,000 X $\frac{1,024,000pts}{50,000,000pts}$ = **Rs.8,192**

Your Bonus Income **Rs.134,772**

"The statements made on this page are hypothetical and merely meant to describe and explain the mechanisms of the Compensation plan and its various bonus features. Any statements made on this page are not meant as earnings claims, nor do they represent any promises or guarantees of specific earnings or earning potential. Specific earnings will be influenced by many factors."

DXN MARKETING PLAN

